



SDT-R series

10 Amp Miniature Power PC Board Relay

Appliances, HVAC, CTV, Monitor Display.

- UL File No. E58304
- CSA File No. LR48471
- SEMKO FileNo. 9722134, 9803052
- TUV File No. R9750487

Features

- Low cost, UL TV-5 and TV-8 rating relay.
- 1 Form A contact arrangement.
- Sensitive and standard coils available.
- Applications include appliance, HVAC, CTV, Monitor, emergency lighting.

Contact Data @ 20°C

Arrangements: 1 Form A (SPST-NO)

Material: AgSnO

Max. Switching Rate: 300 ops./min. (no load).
30 ops./min. (rated load).

Expected Mechanical Life: 10 million operations (no load).

Expected Electrical Life: 100,000 operations (rated load).

Minimum Load: 100mA @ 5VDC.

Initial Contact Resistance: 100 milliohms @ 1A, 6VDC.

Contact Ratings

Ratings:

SDT-LMR & SDT-LMR2: 5A Tungsten @ 120VAC (TV-5) 25,000ops.
5A @ 250VAC resistive,
5A @ 30VDC resistive.

SDT-DMR: 8A Tungsten @ 120VAC (TV-8) 25,000ops.
10A @ 250VAC resistive,
10A @ 30VDC resistive.

Max. Switched Voltage: AC: 250V.
DC: 30V.

Max. Switched Current: 5A (SDT-LMR, SDT-LMR2), 10A (SDT-DMR)

Max. Switched Power: 1,250VA, 150W (SDT-LMR, SDT-LMR2),
2,500VA, 300W (SDT-DMR).

Initial Dielectric Strength

Between Open Contacts: 1,000VAC 50/60 Hz. (1 minute).

Between Coil and Contacts: 4,000VAC 50/60 Hz. (1 minute).

Surge Voltage Between Coil and Contacts: 10,000V (1.2 / 50µs).

Initial Insulation Resistance

Between Mutually Insulated Elements: 1,000M ohms min. @ 500VDCM.

Coil Data

Voltage: 3 to 48VDC.

Nominal Power:

SDT-LMR : 250 mW

SDT-DMR : 540 mW

SDT-LMR 2 : 150 mW

Coil Temperature Rise: 40°C max., at rated coil voltage.

Max. Coil Power: 130% of nominal.

Duty Cycle: Continuous.

Coil Data @ 20°C

SDT-LMR2 (150mW)				
Rated Coil Voltage (VDC)	Nominal Current (mA)	Coil Resistance (ohms) ± 10%	Must Operate Voltage (VDC)	Must Release Voltage (VDC)
3	50.0	60	2.25	0.30
5	30.0	167	3.75	0.50
6	25.0	240	4.50	0.60
9	16.7	540	6.75	0.90
12	12.5	960	9.00	1.20
24	6.2	3,840	18.00	2.40
SDT-LMR (250mW)				
Rated Coil Voltage (VDC)	Nominal Current (mA)	Coil Resistance (ohms) ± 10%	Must Operate Voltage (VDC)	Must Release Voltage (VDC)
3	83.4	36	2.25	0.30
5	50.0	100	3.75	0.50
6	41.7	144	4.50	0.60
9	27.7	325	6.75	0.90
12	20.7	580	9.00	1.20
24	10.5	2,300	18.00	2.40
SDT-DMR (400mW)				
Rated Coil Voltage (VDC)	Nominal Current (mA)	Coil Resistance (ohms) ± 10%	Must Operate Voltage (VDC)	Must Release Voltage (VDC)
3	178.5	17	2.25	0.30
5	106.4	47	3.75	0.50
6	88.0	68	4.50	0.60
9	58.0	155	6.75	0.90
12	44.4	270	9.00	1.20
24	21.8	1,100	18.00	2.40
48	10.9	4,400	36.00	4.80

Operate Data

Must Operate Voltage: 75% of nominal voltage or less.

Must Release Voltage: 10% of nominal voltage or more.

Operate Time: 15 ms max.

Release Time: 5 ms max.

Environmental Data

Temperature Range:

Operating: -30°C to +70°C

Vibration, Mechanical: 10 to 55 Hz., 1.5mm double amplitude

Operational: 10 to 55 Hz., 1.5mm double amplitude.

Shock, Mechanical: 1,000m/s² (100G approximately).

Operational: 100m/s² (10G approximately).

Operating Humidity: 20 to 85% RH. (Non-condensing).

Mechanical Data

Termination: Printed circuit terminals.

Enclosure (94V-0 Flammability Ratings):

SDT-S: Snap-on dust cover (Flux-tight).

Weight: 0.38 oz. (11g) approximately.

Ordering Information

Typical Part Number ▶	SDT	-S	-1	12	L	M	R
<p>1. Basic Series: SDT = Miniature Power PC board relay.</p>							
<p>2. Enclosure: S = Snap-on (Flux-tight)* cover.</p>							
<p>3. Termination: 1 = 1 pole</p>							
<p>4. Coil Voltage: 03 = 3VDC 06 = 6VDC 12 = 12VDC 48 = 48VDC 05 = 5VDC 09 = 9VDC 24 = 24VDC</p>							
<p>5. Coil Input: L = Sensitive (250mW) D = Standard (540mW)</p>							
<p>6. Contact Arrangement: M = 1 Form A, SPST-NO</p>							
<p>7. Construction: R = New construction</p>							
<p>8. Option: 2 = LMR2 (150mW coil version)</p>							

* Not suitable for immersion cleaning processes.

Outline Dimensions

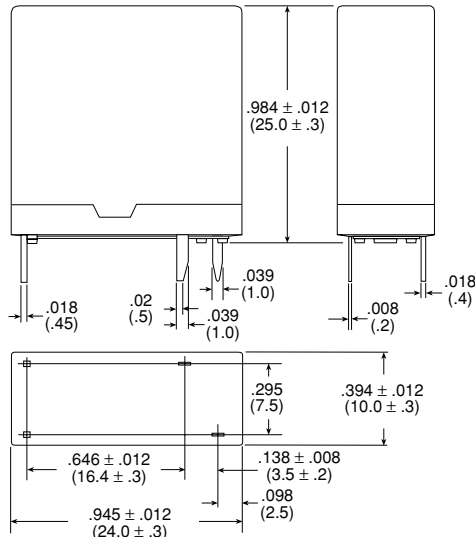

Wiring Diagram (Bottom View)

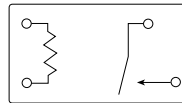

PC Board Layout (Bottom View)

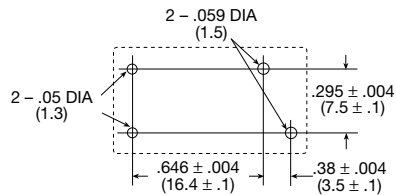

Reference Data

Operating Voltage (SDT-LMR)

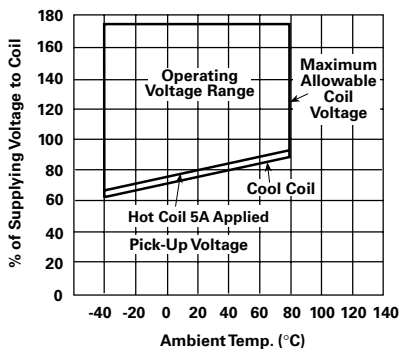

Operate Time

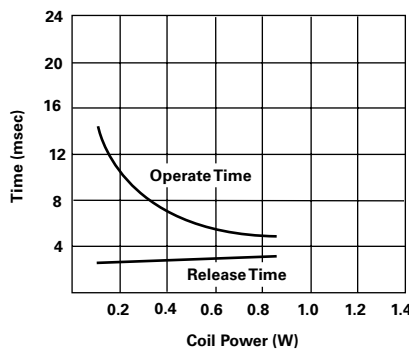

Life Expectancy

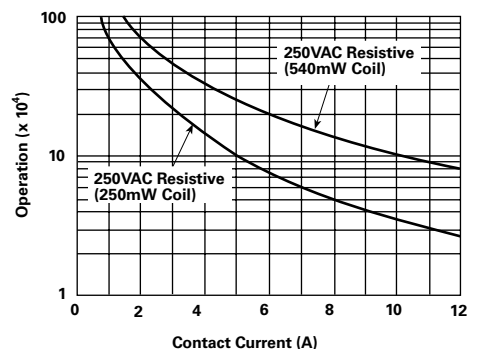

Note: This data is based on the max. allowable temperature for E type insulation coil (115°C).